

Technologies and Components That Protect Digital Relays from Electromagnetic Pulse

Vladimir Gurevich

Central Electrical Laboratory
Israel Electric Corp. Haifa, Israel
vladimir.gurevich@gmx.net

Abstract: Protection of digital protective relays (DPR) from a powerful electromagnetic pulse capable of interfering with their normal functionality or damaging their internal elements has recently gained particular relevance. This article discusses issues related to the electromagnetic pulse's impact on DPR. Technologies and components, the use of which can significantly improve DPR's resistance to electromagnetic pulses are suggested.

Keywords: digital protective relays, HEMP, grounding, EMP.

1. INTRODUCTION

Modern trends of relay protection (RP) development based on the substitution of electro-mechanic protection relays by digital protective relays (DPR) pre-conditioned the emergence of an absolutely new problem, which was not known before. The problem lies in the possibility of Intentional Destructive Remote Impacts (IDRI) on the DPR that either totally puts it out of commission or forces it to perform certain operations, which have nothing to do with the current operation mode of electric equipment being protected. DPR represents the most critical link in the structure of the modern electric power system that is the most susceptible to Intentional Electromagnetic Destructive Impacts (IDEI) on the one hand, while on the other hand it is directly connected with the power circuit breakers influencing the mode of the electric power system. Thus, IDRI represented by cyber attacks and IDEI are aimed at DPR in the first turn. Among others, the most powerful and dangerous impact is represented by the High Altitude Electromagnetic Pulse (HEMP) [1]; and this article discusses the ways of protecting DPR from it.

2. THE ISSUE OF DPR GROUNDING

Large-scale electric power facilities (such as large sub-stations and power plants) do not allow realizing many established methods of efficient grounding as it is inevitable to ground different electric units located at large distances from each other at different points of a general grounding circuit. Moreover, these grounding points gain significant potential differences when large pulse currents flow through the grounding circuit. In the absence of galvanic coupling between these electric units (such as protective relays connected with each other by fiber-optics communication line (FOCL)), the difference of potentials does not play a major role. However, if protective relays located at some distance from each other are connected by means of a cable communication system, i.e.. a twisted pair with an ordinary Ethernet channel (which has recently been largely adopted in order to reduce costs of energy supply), the low-voltage units of this system will be affected by applied high voltage, which will inevitably result in the damage of the system, i.e., in the failure of relay protection, Fig. 1.

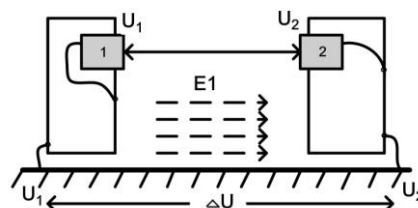

Fig1. Connection diagram of two DPRs (1 and 2) located at significant distances from each other with a non-insulated communication channel (twisted pair or Ethernet)

There are technical solutions on how to establish grounding of highly sensitive electronic equipment in order to protect it from the difference of potentials impact in case of lightning currents or large short-circuit currents flowing through the grounding system elements. These solutions include, for example, connection (bonding) of housings of several inter-related units to a common point (to a common bus) and further connection of this common point (bus) with the common grounding system of a substation or a power plant. This solution is assumed to have no difference of potentials between the inter-related electric units due to the fact that all of their connection points are united in one common point or on one short bus. The same properties can be achieved when connecting the grounding points of separate electric units to the common equipotential plane represented by the elements of metal cabinets, in which these electric units are installed, Fig. 2.

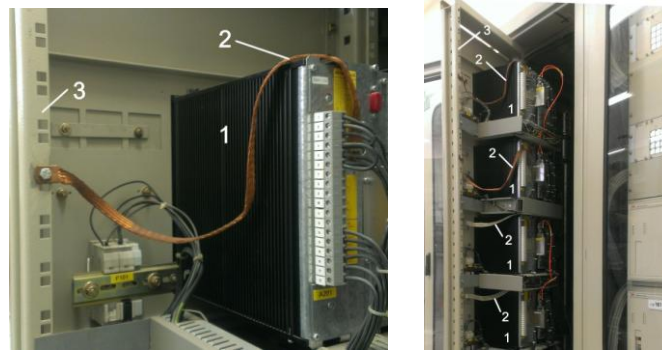

Fig2. DPR's grounding device installed in metal cabinets using the equipotential plane, 1 – DPR in metal housings; 2 – Grounding copper buses (bonding); 3 – Metal cabinet's element, which performs the role of the equipotential plane

The neighboring cabinets are connected to a common grounding bus, which will be connected to the grounding system. These solutions are only possible when electric units (DPR) are connected by galvanic coupling and located at a relatively short distance between each other, such as inside of one cabinet, whereas the cabinets are located within the borders of one relay room. If the units having the galvanic coupling are located in different places over a large territory, this solution will be unacceptable. The larger the physical sizes of the facility, the greater the potential for problems [2].

There are three types of grounding [3]: the so called signal reference (or functional or operational), fault protection, lightning protection. Based on their names it is obvious that the first type is intended for ensuring normal functioning (operation) of equipment, while the other two are only used to ensure electrical safety of employees. The [4] suggests that functional grounding is necessary to ensure DPR functionality; and there are different options for establishment and testing of this kind of grounding. In fact, some printed circuit boards of DPR include cleared and silver-covered sections of wider conductor strips, which touch special springs when the board is installed in the casing ensuring the contact between these conduction strips with the grounded casing of DPR, Fig. 3.

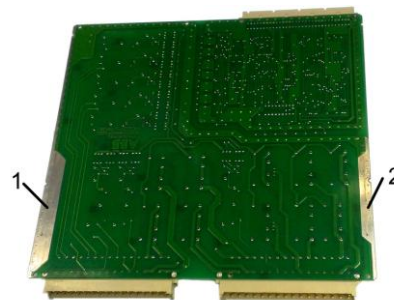

Fig3. The DPR printed circuit board with cleared sections of printed wiring (1 and 2), which contact the grounded casing by means of a special spring

Is the functional grounding really needed for normal operation of DPR, the input and output circuits of which are well insulated from the ground and other electric equipment (when using FOCL to establish the connection between the terminals)? Indeed, the functionality of the internal electronic circuits of a DPR has nothing to do with the availability or lack of grounding. As for the efficiency of protection of the DPR's sensitive electronic circuits from the impact of external electromagnetic fields by means of metal casing, which is intended to act as the "Faraday cage", it should be noted that the

efficiency is not dependent on the availability or lack of grounding. In other words, grounding the DPR's casing does not influence the efficiency of the casing's shielding effect. On the other hand, if the disturbance signals are coming to the electronic circuits of DPR (located inside the casing) via cables, how can grounding of the casing prevent the impact of these disturbances (especially those of the differential type)? The answer is obvious: it cannot! Moreover, it should be mentioned that grounding the DPR casings will only worsen the situation and reduce disturbance resistance of the relay protection. For instance, according to IEC 60255-22-4 all the input and output circuits of relay protection (except for digital communication ports) should be tested by pulse voltage in the nano-second range and an amplitude of 4 kV. That is, it is initially assumed that digital communication ports and circuits will not withstand such tests. But when using an ordinary twisted pair and when connecting these circuits to the Ethernet (instead of FOCL), these circuits will inevitably suffer from the applied high voltage under conditions depicted in Fig. 1. What will change, if DPR casings are thoroughly insulated from the grounding system? If capacitive parasitics are neglected (and the construction discussed below allows neglecting them), then based on Fig. 1, high voltage will not be applied to the digital communication ports.

Another problem of today's grounding system is the High Altitude Electromagnetic Pulse (HEMP), especially its early-time component – E1 – which features short, but very powerful electric field pulses with intensities of up to 50 kV/m, the leading edge of several nano-seconds and the trailing edge of one micro-second [1] at the surface of the Earth. This field has a complex structure and contains vertical and horizontal components, which condition the emergence of significant current pulses in the extended conductors, particularly, in the grounding systems, which act as large antennas absorbing electromagnetic energy from the large area. In the case of lightning charges or puncture of the insulation of high-voltage electric equipment having functionally grounded parts, e.g., grounding of neutrals of high-voltage transformer's windings connected in star-formation, the grounding system acts as an electrode with a zero potential. The majority of regulatory documents, even such serious documents as [5], do not distinguish between the impact of the lightning charge and the E1 component of HEMP. The [5] document literally says: *“Since the influence of EMP-induced interference is similar to that seen by lightning discharges, the lightning subsystem and the earth electrode subsystem are the main interfaces with the EMP protection system”*.

However, there is a significant difference between high-voltage lightning discharges to the grounding system, having neutral potential, or the insulation puncture of high-voltage equipment to the ground and the powerful E1 electric field part of which is directed parallel to the surface of the earth, i.e., parallel to the grid of the grounding system. During HEMP the grounding system stops acting as a zero-potential plane and is converted into a source of high amplitude voltage pulse, applied to electric equipment grounded at different parts of the grounding systems and having galvanic coupling between each other, Fig. 1. Since the issue is about a very powerful and very short, i.e., having high-frequency features, pulse, which establishes field intensity in the air reaching as high as 50 kV/m, it becomes obvious that considerable differences of potentials can emerge even on a short section of a standard grounding system, which significantly exceeds the value registered during the flowing of lightning current through the grounding system. This is why the requirements to insulation strength of input and output DPR's circuits to withstand test pulse voltage of nanosecond range with amplitude up to 4 kV (mentioned in IEC 60255-22-4 standard) are not enough to ensure DPR functionality. Moreover, it is not accidental that I mentioned the DPR casing above as an element, which "is intended to act as the "Faraday cage" and not actually "acting as the "Faraday cage". In fact, metal casings of DPR are rather bad at acting as the "Faraday cage" due to large apertures for screens, keyboards and terminal blocks, Fig. 4.



Fig4. Modern DPR terminals in casings with multiple windows, apertures and openings for screens, buttons, indication panels and other elements

The parameters of the E1 component of HEMP are such that all these apertures in the metal casing favor entering of a powerful electromagnetic wave with an equivalent frequency reaching several Gigahertz inside the DPR casing.



Fig5. DPR terminals installed in standard cabinets with glass doors

Standard metal cabinets where the sets of relay protection devices are located today are also not good for DPR protection from high-frequency electromagnetic fields as they have a fully opened lower (or upper) part intended for penetration of multiple cables. Sometimes they may even have glass doors, which make monitoring of DPR screens and indicators easier without opening the cabinet, Fig. 5. So, one way or another it is necessary to look for alternative solutions to ensure this type of protection.

Thus, it becomes obvious that the only necessary thing is the protective grounding of DPR, which protects employees from electric shock when touching the DPR casing and not the functional grounding.

As for protection from the E1 component of HEMP, it appears that the known technical solutions for grounding systems, applied in the electric energy industry are not only useless due to high resistance on the equivalent frequency of several Gigahertz, but also dangerous for sensitive electronic equipment. This enables us to conclude that the requirement of grounding the DPR's casings is in contradiction to the requirement of ensuring their resistance to HEMP impact. However, since the issue is about protective and not functional grounding, it is obvious that there are other options to ensure personnel safety when operating DPR besides grounding of casings.

3. SOLUTION OF GROUNDING AND RELATED PROBLEMS

In my opinion the solution can be represented by manufacturing the DPR terminal in a thoroughly insulated (plastic) casing and by taking additional measures to prevent the ferrying out of a dangerous potential onto the surface of this casing. These measures can include: covering the LCD screen by a transparent plastic panel; locating control buttons on the surface of the casing through the insulation inserts; using a LED to indicate the panel located on the casing's surface through rigid transparent plastic rods; using insulated optical ports to connect an external computer to the DPR.

Additional measures, which not only ensure personnel safety in the situation of lack of casing grounding, but also improve DPR's resistance to high-voltage impacts on input and output circuits of DPR should be effected by certain changes in their construction.

3.1. Analogue Inputs



Fig6. Section of a module showing the analogue inputs of DPR with installed CT. You can clearly see the primary winding, which consists of 4 coils of flexible insulated black wire.

The elements, which connect the analogue inputs of the DPR with external current and voltage circuits, are an input current transformer (CT) and input voltage transformer (VT). This is why these elements will be affected by the powerful overloads of IDEI initially. The input CTs in DPR are simpler in terms of design. As a rule, this is a multi-loop secondary winding, wound on a ferromagnetic core and a primary winding, which consists of several coils of thick insulated wire, wound above insulated secondary winding, Fig. 6.

The methods of improving the structure's resistance to impacts of powerful impulse voltage are rather simple and include the following:

- encapsulation of the secondary winding by epoxy compound, which is hardened under vacuum conditions, Fig. 7;
- use of a wire in a high-voltage insulation to produce the primary winding;
- use of additional shields and semi-conducting covers, which equalize the electric field in the CT's
- design;
- Application of the ferromagnetic core with insulated surface.

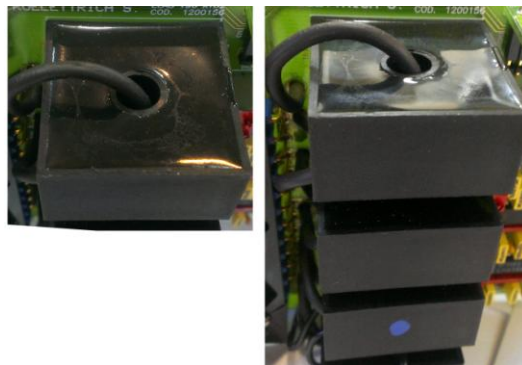

Fig7. Encapsulated current transformers with the secondary winding resting in a plastic case and filled with epoxy compound, hardened under vacuum. You can clearly see the primary winding, which consists of single coil of flexible high voltage insulated wire.

There are many types of flexible wires with high-voltage insulation made of silicone, polyethylene, PTFE and rated for 10-25 kV voltage that are produced by several companies, such as: Teledyne Reynolds, Multi-contact; Allied Wire & Cable; Wiremax; Dielectric Sciences Inc., Axon' Cable, Daburn Electronics & Cable, Sumitomo Electric, Belden and many others.

The recommendations for improving the resistance of VT are similar except for the fact that instead of a flexible wire with a high-voltage insulation as the primary winding, use is made of an ordinary winding wire with improved insulation of Class III (according to IEC 60317-0-1 Specification for particular types of winding wires – Part 0-1: General requirements – Enamelled round copper wire made of polyimide), where both coils are treated under vacuum. Since the increase of cross section of the winding wire automatically results in an increase of insulation thickness and its electric strength, it is recommended using a larger cross section wire regardless of natural increase of the VT's size. Some manufacturers are producing winding wires with insulation made of polyamide, which can resist 1.5 or even double voltage compared with that rated under IEC 60317-0-1. These manufacturers are, for example, the English company P.A.R. Insulations & Wires Ltd, Turkish Bemka A. S. and others.

3.2. Logic Inputs

Insulation of digital (logical) inputs of almost all types of DPRs is provided by optocouplers. As a rule, these are miniature optocouplers in standard casings: DIP-4, DIP-6, DIP-8 and SOP-4. The electric strength of insulation between the inner photo-emitting and photo-receiving elements of these optrons can reach up to 5 -7 kV r.m.s. However, in practice, the optocouplers installed on a printed circuit board cannot withstand these voltages due to the breakdown between the pins over the board's surface. At the same time there are a lot of optocouplers on the market produced in special casings with spatially distributed terminals of inputs and outputs, Fig. 8. These can withstand voltages between the input and output reaching as high as 12 - 25 kV. These are represented by OC100 (Voltage Multipliers, Inc.); HV801 (Amptec, Inc.); OPI1268S (TT Electronics); 5253003120

(Standex Meder Electronics) and other optocouplers. These are the optocouplers that should be used in logic inputs of DPR to improve its resistance to HEMP. The circuits of the DPR are usually constructed in such a way that the first elements to receive the signal applied to logic inputs are implemented by voltage-dependent resistors (TVS-diodes or varistors), which protect the optocouplers' inputs from switching over voltages.

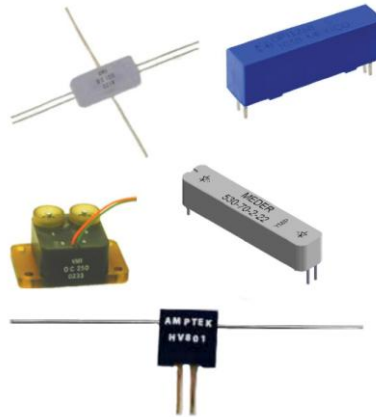

Fig8. Examples of some optocouplers with the voltage strength between inputs and outputs reached up to 12 - 25 kV

The next items that follow the optocouplers are dropping resistors that reduce the input voltage (usually 230 VDC) to the operating voltage of the optocouplers' input circuit, which prevents the current rate of the circuit to exceed a few mill amperes. When using TVS-diodes (see below) instead of varistors, the digital inputs are well protected not only from switching over voltages (as in varistors use), but also from the short high-voltage pulse of the E1 component of HEMP if it succeeds in entering these inputs. Excessively quick time response of modern optocouplers, especially those based on photocells, which can reach as high as 10^{-9} seconds, represents another problem. So, in order to improve disturbance resistance of the optocouplers, it is necessary to provide additional protection from its false actuation during a short E1 pulse. This protection can be provided by by-passing of the optocouplers's input with ceramic capacitors reducing the responsiveness of the optocouplers and thus improving its disturbance resistance.

3.3. Output Relay

One of the measures to improve DPR's resistance to HEMP impact is to use output relays with increased dielectric strength insulation in the DPR. Use of reed switch relays based on the new small size powerful reed switches such as R14U and R15U with double switching stage and produced by Yaskawa company under the BESTACT[®] trade mark is very promising, Fig. 9.

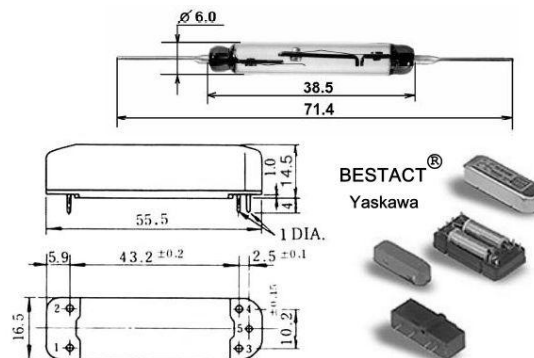

Fig9. Powerful R14U (R15U) reed switch with a double-switching stage contact and a relay based on this reed switch produced by Yaskawa

Reed switches of these types feature a double-stage contact (main and arc-suppression), which allow switching on the active and inductive load at 15A / 220V DC as well as 30A / 220V AC. The company manufactures different relays based on this reed switch, e.g., R1-B14T2U.

The difference of the reed switch relay from other types of electromagnetic relays is the simplicity of construction (reed switch and a coil) and the capability to ensure high level of insulation (dozens

kilovolts) between the coil and the reed switch using simple technical aids. This feature of a reed switch relay is very important when using it as an output relay of DPR, protected from HEMP; this idea can be realized based on my ready-made solutions discussed in [6].

3.4. Printed Circuit Boards

Resistance to pulse voltage by modern printed circuit boards based on SMD technology depends not only on a correct choice of electronic components, but also on breakdown voltage between the elements' pins and between the conduction strips, which can be very small due to high density of mounting. So, one of additional way to improve DPR reliability under HEMP can be by covering the boards with special high-voltage varnish. Examples of this varnish can include 2405-01, 2407-01, etc., products produced by Vol Roll company under the Damicoat® trade mark. The dielectric strength of insulation of this varnish is 70 – 100 kV/mm. Since printed circuit boards with this covering become completely non-repairable, this sets additional requirements on DPR construction: the number of printed circuit boards comprising the DPR should be increased so that if one of the functional modules becomes damaged, only this module need be substituted rather than a large group of functional modules located on a common printed circuit boards. To achieve this, the number of printed circuit boards comprising the DPR should be increased to match the number of functional modules. In other words, each functional module (power source, logic inputs modules, analogue input modules, CPU module and output relay module) should be mounted on a separate sliding printed circuit board, which is connected with other boards by means of a connector via a crossboard.

This approach is not only necessary due to unrepeatability of separate DPR modules, but also preferable to solve the problem of standardization of DPR construction and universalization of its modules [7].

Another advantage of such DPR construction, which consists of several non-repairable functional modules, lies in a possibility of using a new (from the viewpoint of the relay protection) criterion of evaluation of reliability instead of a very strange (here I choose my words carefully) criterion called: "Mean Time Between Failures" - MTBF with its fantastic figures of 50 – 90 years, which have nothing to do with real, nor fictional reliability. This criterion is called "Gamma-percentile operating time to failure" and shows operational time during which the unit's failure is excluded with a certain level of probability, denoted in percentage. For instance, 95% percentile operating time to failure during at least 5 years means that the failure rate of operating units should not exceed 5% during these five years. Having this convenient and clear indicator the user could track the number of out of order modules within a certain period of time and make corresponding claims to a manufacturer, if significantly more modules failed during the established period than the amount warranted by the manufacturer. This indicator will make it easier for the user to surf in the future market of universal modules [7], selecting the most appropriate option in terms of price/quality ratio. In addition to this manufacturers are required to mention the average operation life of separate modules in their technical and bidding documents as well as provide recommendations regarding the frequency of preventive substitution of these modules in order to maintain a high level of reliability of relay protection. For instance, for power supply module this can be 8-10 years; for logic input module – 12 years; for CPU module – 15 years; for analogue input module – 17 years, etc. These data should be known to a responsible manufacturer tracking failure and breakage statistics of its products.

3.5. HEMP Filters

All inputs and outputs of the DPR (excluding the optical digital communication ports) should be connected to external circuits through special filters that protect internal electronic circuits of the DPR from HEMP. Quite a few of large companies manufacture and widely promote such filters as an efficient means of protection against HEMP entering into internal electronic circuits of equipment. Deeper analysis of the issue has revealed that many such filters do not have built-in overvoltage limiters. When I asked the manufacturers about how these filters protect from high-voltage HEMP, many of them didn't even answer. A specialist of one of the manufacturers honestly admitted that my question is correct and substantial and that their filters protecting from HEMP need to be supplemented with external elements protecting from high voltage pulse. Another problem is that some of the HEMP filters (even though they have built-in limiters of pulse voltage at their input terminals) cannot really protect from a very short E1 pulse due to the lack of response time of varistors and gas-discharge tubes used as the limiters of pulse voltage amplitude, Fig. 9.

Unfortunately, one of the manufacturers didn't even address my request on how a relatively slow element such as a varistor or even slower gas-discharge tubes can protect from a short E1 pulse.



Fig10. HEMP filters manufactured by the MPE company, which include voltage depended resistors - VDR (varistors) and gas-discharge tubes (GDT) as elements protecting from high voltage pulse

A really responsive element capable of limiting the amplitude of a powerful and short E1 pulse is represented by the so called transient voltage suppressor diodes (TVS Diodes), based on silicone avalanche diodes. This type of element is manufactured by many companies, Fig. 10.



Fig11. Powerful and responsive suppressors, based on avalanche diodes

The most powerful TVS-diodes (pulse current up to 10 kA, discharge voltage – 200-500V) are manufactured by Bourns, Inc. These limiters are part of filters of Captor Corp, fig. 12 and they are recommended when designing a protected DPR.

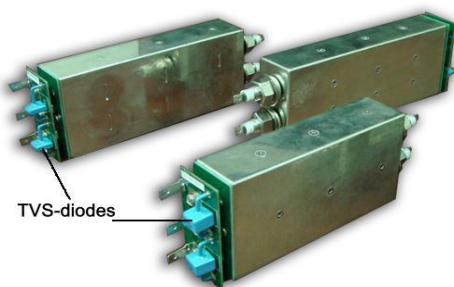

Fig12. HEMP filters manufactured by Captor Corp. and equipped with powerful and responsive suppressors based on TVS-diodes

3.6. Control Cables

Control cables should definitely be shielded and with twisted pair. The minimum requirement to the screen is a high density of braid (not less than 85%). However, double-braided cables are much better at providing shielding. Cable braid provides better shielding than a foil at relatively low frequencies (up to several Megahertz) mainly due to its thickness. However, further on the shielding properties of the braid dramatically deteriorate and become unacceptable before even reaching 100 MHz. At the same time foil has a flat amplitude and frequency characteristic in the high frequency range while maintaining satisfactory shielding properties up to several Gigahertz, Fig. 13.

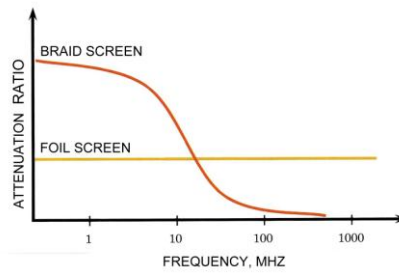

Fig13. Shielding coefficient as a function of frequency for screens made of braid and foil

So, preference should be given to cables with compound multi-layer screen containing both a braid and foil, Fig. 14.

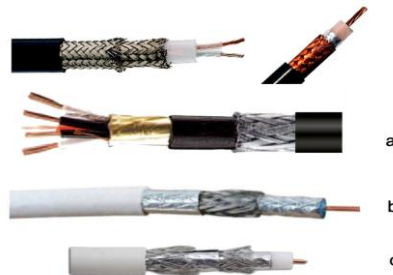

Fig14. Cables with double (a), triple (b) and four-layer (c) compound (braid + foil) shielding capability

Obviously, new projects should use special types of control cables, which combine pair twisting of cables and foil screens for each of these pairs with a three-layer common compound screen, e.g., 48-core cable, such as RE-2X(ST)2Y(Z)Y PIMF. This is an ideal case. However, what should we do with dozens of old-style control cables brought into existing cabinets of relay protection? Should we change them to new cables? In many situations this can be too complicated and too expensive. Luckily, some companies, e.g., Holland Shielding Systems BV, manufacture special wrap shield materials, which can be used to cover old-style non-shielded control cables as well as screening sleeves, which can be put on non-shielded and poorly shielded cables, Fig. 15.



Fig15. Materials for shielding of non-shielded cables

3.7. DPR Composition Inside a Relay Cabinet

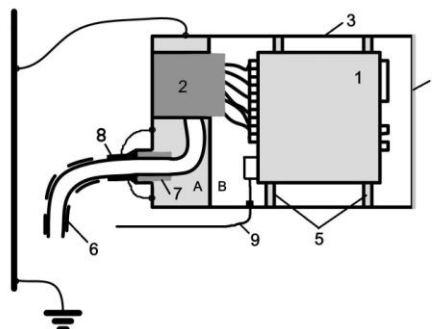

Fig16. Suggested DPR configuration, which ensures increased resistance to HEMP, A – "dirty" zone; B – "clean" zone; 1 – DPR terminal in a thoroughly insulated plastic casing; 2 – HEMP filter; 3 – steel casing; 4 – steel casing door; 5 – insulators; 6 – double-shielded control cable; 7 – wall tube; 8 – metal socket to couple cable braid with steel casing; 9 – FOCL

As mentioned above standard constructions of relay cabinets that are widely used in the electric power industry today cannot be considered as a reliable means of HEMP protection. At the same time, DPR produced in a fully insulated non-conducting cases (as those suggested above) should be reliably protected from both external electromagnetic fields and pulse voltage coming through external cables. How can we combine these requirements?

I think, the problem can be solved by locating a DPR with insulated case inside an additional steel container manufactured according to a corresponding technology, Fig. 16.

Standard containers and cabinets made of sheet steel and containing no windows or apertures significantly reduce the electromagnetic field's pulse. However, use of galvanized sheets for their production as well as special conductive sealers and gaskets results in a significant improvement of their efficiency, since zinc priming enables leveling up the potentials on a large surface area (electrical resistivity of steel is 0.103-0.204 Ohm x mm²/m, while electrical resistivity of zinc is 0.053-0.062 Ohm x mm²/m). Aluminum has even lower resistance (0.028 Ohm x mm²/m). This is why some companies use special alloy, for example, Aluzinc®, when manufacturing containers and cabinets. This steel has a special covering, which consists of 55% aluminum, 43.4% zinc and 1.6% silica. The surface containing this covering provides a high level of reflectance of electromagnetic radiance. The level of weakening of external radiation by container manufactured under this technology amounts to 80-90 dB in 100 kHz – 10 GHz frequencies interval.

Container 3, Fig. 16, is divided by internal partitioning into two zones: A – "dirty" and B – "clean". The DPR terminal in the plastic casing is located in the clean zone, which is free from electromagnetic radiance. Container 3 has a door 4, which provides staff access to the face panel of the DPR during maintenance. Container 3 is grounded meeting all traditional regulations and rules of grounding; this ensures fulfillment of operational safety requirements. Considering the rather large distance between the DPR and internal walls of grounded metal container, e.g., 5 - 7 cm, parasitic capacitance of electronic circuits of DPR to the ground will be very insignificant and its impact can be neglected, which was mentioned above.

4. CONCLUSION

The problem of improvement of DPR resistance to HEMP is complex and comprehensive. So, the efforts of power engineers that use DPR to solve the problem are obviously not enough. DPR manufacturers should also get involved in the solution of the problem. Only joint efforts will result in an efficient solution of the problem. The technologies and components discussed in this article can act as the basis for a successful solution of the problem.

REFERENCES

- [1] Gurevich V. Cyber and Electromagnetic Threats in Modern Relay Protection - CRC Press (Taylor & Francis Group), Boca Raton – New York – London, 2014, 222 p.
- [2] Whitaker J. C. Electronic Systems Maintenance Handbook, Second Edition - CRC Press (Taylor & Francis Group), Boca Raton – New York – London, 2001, 624 p.
- [3] MIL-STD-188-124B Grounding, Bonding and Shielding, DoD, 1992.
- [4] Ilyin V. F., Ilyin N.V. Grounding in Microprocessor Protection Cabinets. – Relay Protection and Automatization, 2015, No. 1, pp. 26 – 30.
- [5] Grounding and Bonding in Command, Control, Communications, Computer, Intelligence, Surveillance and Reconnaissance (C4ISR) Facilities. – Technical Manual TM 5-690, Headquarters Department of the Army, 17 February 2002.
- [6] Gurevich V. Protection Devices and Systems for High-Voltage Applications – Marcel Dekker, New-York – Basel, 2003, 293 p.
- [7] Gurevich V. Problems of Standardization in Relay Protection – DEAN, St.- St. Petersburg, 2015, 168 p.

AUTHOR'S BIOGRAPHY



Vladimir I. Gurevich, was born in Kharkov, Ukraine, in 1956. He received an M.S.E.E. degree (1978) at the Kharkov Technical University, named after P. Vasilenko, and a Ph.D. degree (1986) at Kharkov National Polytechnic University. His employment experience includes: teacher, assistant professor and associate professor at Kharkov Technical University, and chief engineer and director of Inventor, Ltd. In 1994, he arrived in Israel and works today at Israel Electric Corp. as a senior specialist and Head of section of the Central Electric Laboratory.

He is the author of more than 180 professional papers and 12 books and holder of nearly 120 patents in the field of electrical engineering and power electronics.

In 2006 he was Honorable Professor with the Kharkov Technical University.