

Disaster Management System Using GSM

Arathi H¹, Archana M S², ParvatiMadevaGond³, Shayana A Hegde⁴,
Guided by Asst. Professor Ganesh Shetty

Electronics and Communication, VTU, Moodlakatte Institute of Technology Kundapur
¹h.arathi.billava@gmail.com, ²archanams505@gmail.com, ³parvatigond30@gmail.com,
⁴shayana.hegde18@gmail.com

Abstract: *The natural disasters like earthquake, tsunami and landslide as the occurrence of these disasters is a big loss for human life and property. Natural causes cannot be stopped but using this technique can alert people before it occurs. In this design, five sensors are used, those are angle or tilt sensor which gives the readings of slope angle if there is any movement due to the landslide and it is also used for tsunami alerting purpose, rain gauge sensor is used to collect the depth of water at the mountains, soil drift sensor is used for detection of landslide, earthquake sensors are used for earthquake detection purpose and temperature sensor is used for collecting the temperature. If any disaster occurs, sensor will sense the signal and output of sensor will given to the PIC microcontroller for further process. These all nodes of sensors are connected to the PIC controller for collection of data and obtained information is transmitted to the receiver section using RF module. Alerting message display on LCD and message is sent in order to alert the people. Thus this project is very important as this is used for real time purpose for saving lives and property also this design combines the GSM wireless communication technology.*

Keywords: *Sensors, PIC microcontroller, GSM*

1. INTRODUCTION

This paper is mainly deals with natural disasters. A natural disaster is a major adverse event resulting from natural process of the Earth. Landslide monitoring is an important topic related at the hill slides. Landslide is downward and outward movement of slope forming materials composed of rocks, soils, artificial fills or combination of all these materials along surfaces of separation by falling, sliding and flowing, either slowly or quickly from one place to another [1]. Most of the case happens without of human awareness. Landslides are geological phenomenon causing significant loss of life and properties damages each year in many countries. Many factors contribute to landslides, they are natural factors like Gravity, Geological factors, heavy and prolonged rainfall, and Earthquakes [2]. Earthquakes are a form of wave energy that is transferred through bedrock. Motion is transmitted from the point of sudden energy release, the earthquake focus as spherical seismic waves that travel in all directions outward as shown in Fig.1.2. The point on the Earth's surface directly above the focus is termed the epicenter. Two different types of seismic waves have been described by geologists: body waves and surface waves. Body waves are seismic waves that travel through the lithosphere. Two kinds of body waves exist: P-waves and S-waves. Both of these waves produce a sharp jolt or shaking. P-waves or primary waves are formed by the alternate expansion and contraction of bedrock and cause the volume of the material they travel through to change. They travel at a speed of about 5 to 7 kilometers per second through the lithosphere. The speed of sound is about 0.30 kilometers per second. P-waves also have the ability to travel through solid, liquid, and gaseous materials. When some P-waves move from the ground to the lower atmosphere, the sound wave that is produced can sometimes be heard by humans and animals. S-waves or secondary waves are a second type of body wave. These waves are slower than P-waves and can only move through solid materials. S-waves are produced by shear stresses and move the materials they pass through in a perpendicular (up and down or side to side) direction [3]. Tsunami is a series of water waves caused by the displacement of a large volume of a body of water, usually an ocean. A Tsunami is a very long-wavelength wave of water that is generated by earthquakes that causes displacement of the seafloor, but Tsunami can also be generated by volcanic eruptions, landslides and underwater explosions [1].

This design is using five sensors. The LM35 temperature sensor is used for collecting temperature. Angle or tilt sensor is used to sense slope angle, if there is any movement in landslide and it is also used

for tsunami purpose. Rain gauge sensor is used to collect the depth of water at the mountains. Earthquake sensors are used for earthquake purpose. Soil drift sensor is used for landslide. If any drift or variation occurs, output of sensor will send to the PIC controller for further process. These all nodes of sensors are connected to the PIC controller for collection of data. And obtain the information at the receiver side by LCD display or by SMS. This is used to alert the people, save lives and property. Thus this project is very important as this is used in our real time purpose for saving lives and property. This design combines of GSM wireless communication technology and able to inform quickly to the user or to the responsible authority if the sensor is activated.

2. LITERATURE SURVEY

2.1. “Wireless Sensor Network Forlandslide Assessment” by mr.Sagar D.Solanki and Mr. Ankit Suthar [4].

Natural disasters are increasing worldwide due to the global warming and climate change. They are focusing on Landslides disaster. However, this disaster is largely unpredictable and occurs within very short spans of time. Therefore technology has to be developed to capture relevant signals with minimum monitoring delay. Wireless Sensors are one of the cutting edge technologies that can quickly respond to rapid changes of data and send the sensed data to a data analysis centre in areas where cabling is in appropriate. The heart of this project lies with the use of a GSM, Zigbee and Sensor. Every sensor has Zigbee Transmitter mounted on it. When landslide happens, sensor senses the signal and transfer data through router to the coordinator. Coordinator has GSM and Zigbee Rx. Coordinator receives it and this information is transmitted by GSM to the Control centre. GSM in the Control centre receives this and transfer this information via GSM to rescue team. This also checks the status of sensor by sending message. Monitoring Landslides is very helpful to protect people and avoid accident. Because of landslides many accident occur on highway, hill station and railway track. So with the help of this system, they can warn the main centre about where the landslides happen. They also check the status of tunnels and landslides prone area.

2.2. “An Automated Tsunami Alert System” by Ramya and B.Palaniappan [5].

The tsunami waves cause considerable destruction and kills people. The detection section of the proposed system consists of a microcontroller and a capacitive sensor to detect the Tsunami occurrence. The principle is as follows, on the onslaught of Tsunami or any other natural calamity of this type, there is an abnormal pressure rise in the seafloor. Here a proximity capacitive sensor is used which gives an output depending on capacitance variations, and a microcontroller is used to announce the oncoming of Tsunami event to a concerned person, through mobile computing. Mobile is used to send warning messages.

2.3. “Simulation of Earthquakes and Tsunami through GSM Network” by G.Saradha [6].

In GSM-based seismic alert system that could warn before an earthquake strikes. Earthquakes strike without warning. The resulting damage can be minimized and lives can be saved if people living in the earthquake-prone area are already prepared to survive the strike. This requires a warning before strong ground motion from the earthquake arrival. Such a warning system is possible because of energy wave released at the epicentre of the earth quake travels slower than light. The warning signal from the earthquake epicentre can be transmitted to different places using satellite communication network, fibre-optics network, pager service, Cell phone services or a combination of these. The satellite-based network is ideal when an alert system has to cover a large country like India. For earthquake-prone states like Gujarat, a seismic alert system using the global system for mobile communication network spread throughout the state is proposed.

2.4. “Real-time Wireless Sensor Network for Landslide Detection” by Maneesha V. Ramesh [7].

Wireless sensor networks are one of the emerging areas which have equipped scientists with the capability of developing real-time monitoring systems. This paper discusses the development of a wireless sensor network(WSN) to detect landslides, which includes the design, development and implementation of a WSN for real time monitoring, the development of the algorithms needed that will enable efficient data collection and data aggregation, and the network requirements of the deployed landslide detection system. The actual deployment of the test bed is in Idukki district of the Southern state of Kerala, a region known for its heavy rainfall, steep slopes, and frequent landslides.

2.5. “An Internet-enabled wireless multi-sensor system for continuous monitoring of landslide processes” by Kay Smarsly, Kristina Georgieva and Markus König [8].

Monitoring and early warning systems, although being capable of continuously collecting field data related to landslide processes, are usually unable to autonomously detect and analyze signs of landslides in real time. This paper presents the design and experimental implementation of an autonomous landslide monitoring system. Besides reliably issuing early warnings in case of detected slope anomalies, the monitoring system is primarily designed to support human individuals in assessing the risk of landslide and to improve the understanding of the slope behavior, which may help to reduce economic losses and fatalities caused by landslides. Specifically, intelligent wireless sensor nodes are distributed in the observed slope to autonomously collect, analyze and communicate relevant environmental parameters in real time. Supporting remote analyses of the collected field data, a web application, which is installed on a computer connected to the on-site sensor nodes, enables an automated dissemination of slope parameters through the Internet. Last but not least, geospatial information stemming from external sources is integrated into the monitoring system to provide a comprehensive overview of landslide-related slope conditions.

3. SYSTEM ARCHITECTURE

3.1. Introduction

This design consists of five sensor, RF and GSM module. The sensors used are tilt sensor, soil drift sensor, earthquake sensors, rain gauge sensor and temperature sensor. Output of sensor will send to the PIC controller for further process. Using RF transmitter, signal is transmitted to receiver. These all nodes of sensors are connected to the PIC controller for collection of data. It obtains the information at the receiver side by LCD display at receiver station or by SMS.

3.2. Transmitter

Below is the block diagram showing the transmitter section of the system architecture.

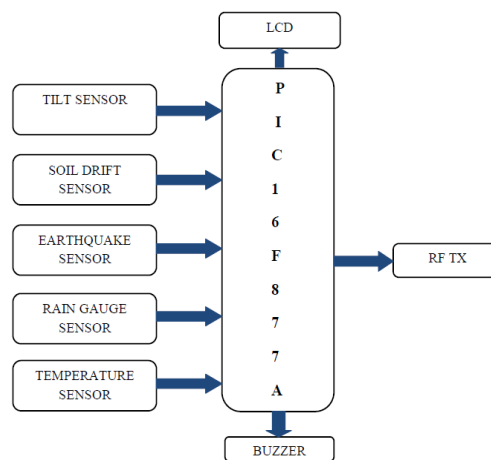

Fig1. Block diagram of transmitter section

Tilt Sensor: Tilt sensor which senses slope angle if there is any movement in landslide and it is also used for tsunami purpose. This Tilt sensor acts as a switch, switches employ a mercury bead which connects its terminals whenever it is tilted. Then mercury is being a liquid metal can flow down and establish contact between the leads of the switch in this way sensor is activated.

Soil Drift Sensor: Soil drift sensor is used for landslide. If any drift or variation occurs, output of sensor will send to the PIC controller for further process. This sensor is designed using transistor when base of this transistor is activated.

Earthquake Sensor: Piezoelectric sensor converts mechanical vibrations into electrical variations. Electrical pulses are undergone amplification by transistor amplifier stages. Final transistor drives output port of PIC microcontroller is high.

Rain Gauge Sensor: When transistor base comes in contact with the water, the 5V is passes through the water and base will be triggered. The base triggering current will be 5mA and voltage is 2.5V. This is sufficient to trigger the transistor base. In this way the sensor is activated.

Temperature Sensor: LM35 series are precision integration-circuit temperature sensors whose output voltage is linearly proportional to the Celsius temperature. The LM35 does not require any external calibration or trimming to provide typical accuracies. This is three legs IC that directly gives analog output. This unit requires +5VDC for it proper operation

Pic16f877a Microcontroller: PIC16F877A microcontroller has five ports (Port A, B, C, D & E) this is the first advantage of this PIC. It has 40 pins on it and 33 of them can be used as IO. Port A issued to connect the sensor output, Port B is used for LCD, Port C is used to control RF module. Port D is used to connect the motor, GSM and LED. Port E is used to connect the key.

3.3. Receiver

Below is the block diagram showing the receiver section of the system architecture.

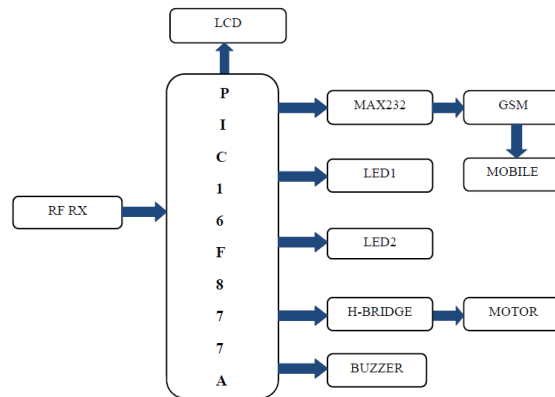

Fig2. Block diagram of receiver section

RF Module: RF module consisting of transmitter and the receiver section is used to transmit the signal from transmitter section to the receiver section.

GSM: GSM wireless communication technology used to send the alert message to the responsible authority if the sensor is activated.

4. CIRCUIT DIAGRAM

This design consists of five sensor, RF module and GSM module. The sensors used are tilt sensor, soil drift sensor, earthquake sensors, rain gauge sensor and temperature sensor. Output of sensor will send to the PIC controller for further process. Using RF transmitter, signal is transmitted to the receiver. These all nodes of sensors are connected to the PIC controller for collection of data. It obtains the information at the receiver side by LCD display at receiver station or by SMS.

4.1. Transmitter Section

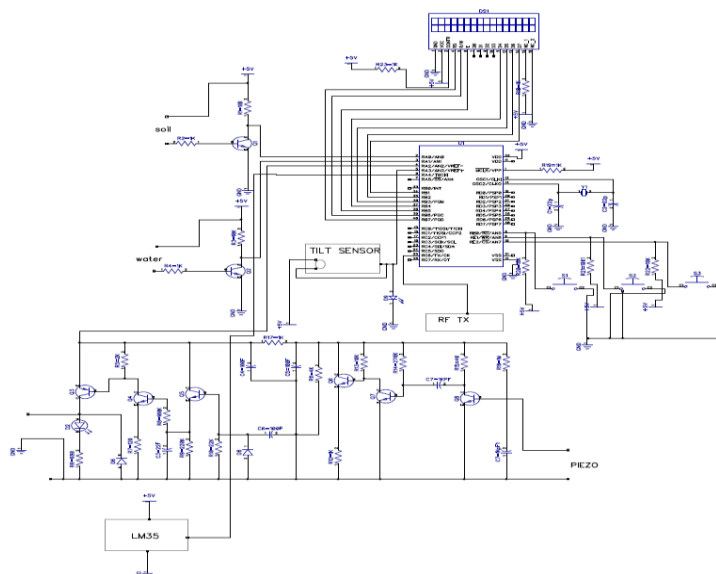

Fig3. Circuit diagram of transmitter section

RA0 of PIC microcontroller is connected to the output pin of the soil drift sensor. RA1 pin of PIC microcontroller is connected to output pin of the rain gauge sensor. RA2 pin of PIC controller is connected to output pin of the earthquake sensor. RA3 pin of PIC microcontroller is connected to output pin of the tilt sensor. RA4 pin of PIC microcontroller connected to the output pin of the Temperature sensor. So that sensed value is read by controller and it compares some threshold value. RE0, RE1, RE2 pins of microcontroller is connected to the up, down, enter switch. RB4 to RB7 pins of PIC microcontroller is connected to the LCD. In 4-bit mode of operation, for the sake of saving valuable I/O pins of the microcontroller, there are only 4 higher bits (D4-D7) used for communication, while other may be left unconnected. Pin13 and pin 14(Osc/CLK) is connected to crystal oscillator to generate clock frequency of 20MHz. RC6 pin of microcontroller is connected transmitter part RF module for transmitting the signal to receiver section.

4.2. Receiver Section

The transmitted signal is received by RF receiver that is connected to the pin RC7 of microcontroller. The received data is given to PIC microcontroller. RD4 and RD5 pins of microcontroller given to Tx and Rx of MAX232 for serial communication respectively. GSM is connected to it in order to send the alerting message. RD0 and RD2 pins of microcontroller connected to H-bridge circuit to run geared motor. RD2 and RD3 pins are connected to the LED. LCD is connected to the PORT B of PIC controller in order to display the alerting message.

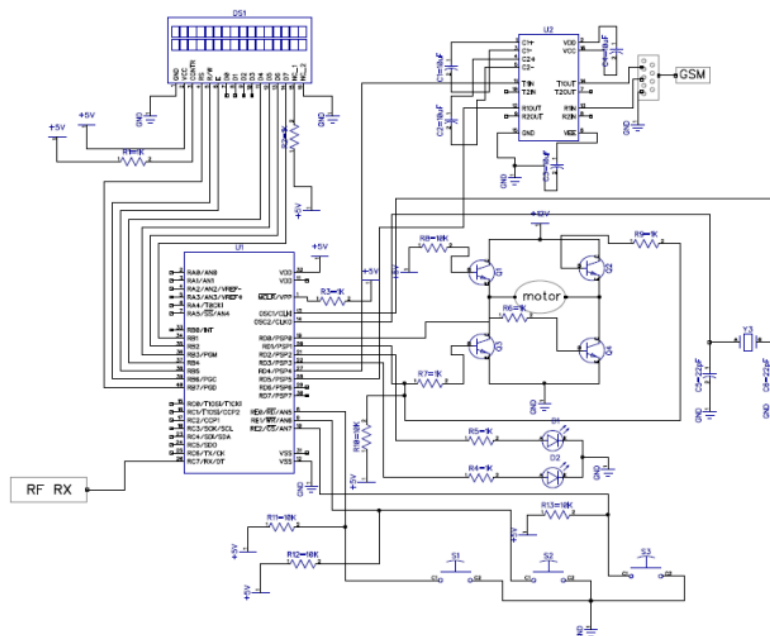

Fig4. Circuit diagram of receiver section

5. HARDWARE DIScription

In this design a system that can alert before these disasters occur. This design uses five sensors. The LM35 temperature sensor is used for collecting the temperature. Angle or tilt sensor which gives the readings of slope angle if there is any movement in landslide and it is also used for tsunami purpose. Rain gauge sensor is used to collect the depth of water at the mountains. Earthquake sensors are used for earthquake purpose. Soil drift sensor is used for landslide. This circuit will measure the soil resistance. If any drift or variation occurs, output of sensor will send to the PIC controller for further process. These all nodes of sensors are connected to the PIC controller for collection of data. As it obtained the information at the receiver side by LCD display or by SMS, it can alert the people, save lives and property. This project is very important as it is used in real time purpose for saving lives and property. This design combines of GSM wireless communication technology and able to inform quickly to the user or to the responsible authority if the sensor is activated.

5.1. PIC16F877A Micro Controller

PIC16F877A microcontroller has five ports (Port A, B, C, D & E). This is the first advantage of this PIC. It has 40 pins on it and 33 of them can be used as IO. Port A issued to connects the sensor output, Port B is used for LCD, Port C is used to control RF module. Port D is used to connect the motor, GSM

and LED, and Port E is used to connect key. In order to make this PIC16F877A work, both power connections (V_{dd}, V_{ss}) should be connected and MCLR should be connected to V_{dd} voltage. If reset is going to be used then a resistor should be connected to MCLR to avoid short circuit. This PIC requires an external crystal to get it work. In this project, a 20 MHz oscillator crystal is used and two 22pF capacitors are used with this crystal.

PIC16F877A has three timer modules (timer0, timer1 and timer2). It has a USART interrupt on PINC7 as receiver and PINC6 as transmitter. Crystal oscillator is connected to 13 and 14 pin numbers of the PIC controller. This PIC also has Analog-To-Digital module, PWM modules and lots of interrupts which is not used in this project [2].

5.2. Sensors

5.2.1. Earthquake Sensor

Piezoelectric sensor converts mechanical vibrations into electrical variations. Electrical pulses are undergone amplification by transistor amplifier stages. Final transistor drives a piezo buzzer. Time delay can be changed by adjusting value of capacitor connected across 220k resistors. To activate AO loads buzzer may be replaced with a relay. Load to be controlled can be connected via normally opened contacts of the relay. For demonstration a 9v battery can be used. For continuous use alarm may be powered using 9V or 12V AC adaptor. Simple unregulated supply is enough. This alarm can be used to protect car and other vehicles. Other application of this project is an earthquake warning alarm. This sensor is connected to pin number 4 of the PIC controller.

5.2.2. Soil Drift Sensor

When transistor base comes in contact with the soil, the 5V is passes through the soil and base will be triggered. The base triggering current will be 5mA and voltage is 2.5V. This is sufficient to trigger the transistor base. When transistor is triggered, then collector terminal of the transistor goes low. This will be applied to the microcontroller. Same circuit can be adapted to the digital and analog mode by altering the program. In analog mode, voltage varies from 0 to 4.7V linearly. In digital mode, value obtained is logical high and low. Total power consumption of the circuit is 5mA to 6mA. This sensor is connected to pin number 2 of the PIC controller.

5.2.3. Tilt Sensor

These switches employ a mercury bead which connects its terminals whenever it is tilted. Then mercury is being a liquid metal can flow down and establish contact between the leads of the switch. The blob of mercury is able to provide resistance to vibrations as mercury is a dense liquid metal [3]. Using mercury is discouraged as it is a toxic metal and poses a potential hazard to the user when the glass casing breaks and metal spillage take place. This sensor is connected to pin number 5 of the PIC controller.

5.2.4. Rain Gauge Sensor

When transistor base comes in contact with the water, the 5V is passes through the water and base will be triggered. The base triggering current will be 5mA and voltage is 2.5V. This is sufficient to trigger the transistor base. When transistor is triggered, then collector terminal of the transistor goes low. This will be applied to the microcontroller. This sensor is operating in digital mode. The power consumption of the circuit is 5mA to 6mA. This sensor is connected to pin number 3 of the PIC controller.

5.2.5. Temperature Sensor

The LM35 series are precision integrated-circuit temperature devices with an output voltage linearly-proportional to the Centigrade temperature. The LM35 device has an advantage over linear temperature sensors calibrated in Kelvin, as the user is not required to subtract a large constant voltage from the output to obtain convenient Centigrade scaling. The LM35 device does not require any external calibration or trimming to provide typical accuracies of $\pm 1/4^\circ\text{C}$ at room temperature and $\pm 3/4^\circ\text{C}$ over a full -55°C to 150°C temperature range. Lower cost is assured by trimming and calibration at the wafer level.

The LM35 device draws only 60 μA from the supply. It has very low self-heating of less than 0.1°C in still air. The LM35 device is rated to operate over a -55°C to 150°C temperature range, while the

LM35C device is rated for a -40°C to 110°C range (-10° with improved accuracy). This sensor is connected to pin number 6 of the PIC controller.

5.3. RF Module Pair (Transmitter And Receiver) 433mhz

The transmitter Module employs a crystal-stabilized oscillator, ensuring accurate frequency control for best range performance. There is no requirement of external RF components except Antenna. RF transmitter is connected to pin number 25 of the PIC controller. The transmitter employs a SAW-stabilized oscillator, ensuring accurate frequency control for best range performance. Range of transmitter is 100 meters when operated at 12V. If it is operated with 5V then range will be 50-60 meters. RF receiver is connected to pin number 26 of the PIC controller. Range will also depend on receiver sensitivity. RF module is used to send the signal from transmitter to receiver.

5.4. GSM SIM900

The baud rate can be configurable from 9600-115200 through AT command. Initially Modem is in Auto baud mode. This GSM -RS232 Modem is having internal TCP/IP stack to enable you to connect with internet via GPRS. It is suitable for SMS as well as DATA transfer application in M2M interface. The modem needed only 3 wires (Tx, Rx and GND) except Power supply to interface with microcontroller/Host PC. The built in Low Dropout Linear voltage regulator allows you to connect wide range of unregulated power supply (4.2V -13V) and 5V is in between them. Using this modem, you will be able to send SMS. GSM modem, works on frequencies 850 MHz, 900 MHz, 1800 MHz and 1900MHz. It is very compact in size and easy to use as plug in GSM Modem. The Modem is designed with RS232 Level converter circuitry, which allows you to directly interface PC Serial port.

5.5. Power Supply Regulation Stage

All digital circuits require regulated power supply. Fig. shows the basic block diagram of a fixed regulated power supply. Let us go through each block.

Step down Transformer: Step down transformer is used to reduce the voltage according to the required voltage of the circuit. Most of the circuit needs 5V to 12V only. Here it used 12V transformer to get 12V as output by giving 230V as input.

Bridge Rectifier: The output from the transformer is in AC, but the supply for circuit in DC. So it needs to rectify the AC output to DC output. So the diodes are used to build a Bridge rectifier circuit to convert the 12VAC to 12VDC. A smoothing capacitor can be used at the output side of the rectifier to get a constant voltage. Bridge Rectifier consists of four diodes namely D1, D2, D3 and D4. During the positive half cycle diodes D1 & D4 conduct whereas in the negative half cycle diodes D2 & D3 conduct.



Fig5. Block diagram of power supply

Voltage Regulator 7805: The output DC voltage now available is 12V but it has to be converted into 5V since the transistor base voltage should be in the range of 5V-6V. Voltage regulators are used in the circuits to provide a constant required voltage and to avoid major fluctuations in the voltage to the circuit. It has 3 pins. The input pin, ground pin and output pin. The input voltage must be within the range of 5V to 30V. So the voltage regulator regulates the voltage to 5V.

6. SOFTWARE DISCRIPTION

6.1. MPLAB IDE

MPLAB[®] X IDE is a software program that runs on a PC to develop applications for Microchip microcontrollers and digital signal controllers. It is called an Integrated Development Environment (IDE), because it provides a single integrated "environment" to develop code for embedded microcontrollers. The peripherals and the amount of memory an application needs to run a program largely determines which PIC micro MCU to use. Other factors might include the power consumed by the microcontroller and its "form factor" (i.e., the size and characteristics of the physical package that must reside on the target design).

7. RESULT AND DISCUSSION

Below figure shows the transmitter section and receiver section of the system.



Fig6. Transmitter Section

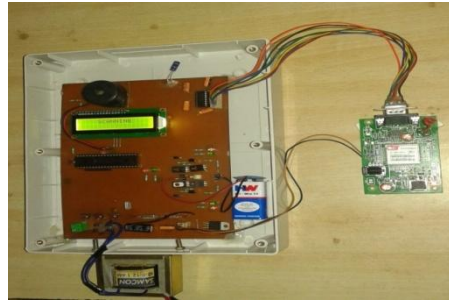

Fig7. Receiver section

7.1. Land Over Dry

When the temperature exceeds more than the threshold value, temperature sensor is activated, alerting message is displayed in the LCD screen as shown in the figure and it also sends SMS to the authority in the base station as shown below.



Fig8. Alerting message for land over Dry

7.2. Heavy Rain Fall

Intensity of the rainfall exceeds the normal range, then rain gauge sensor is activated, alerting message is displayed in the LCD screen as shown in the figure and it also sends SMS to the authority in the base station as shown below.



Fig9. Alerting message for over rain

7.3. Earthquake

When any vibrations in the earth, then earthquake sensor is activated and alerting message is displayed in the LCD screen as shown in the figure and it also sends SMS to the authority in the base station as shown below.



Fig10. Alerting message for Earthquake

7.4. Tsunami and Landslide

When the tilt sensor senses any changes in slope angle, it activated and alerting message is displayed in the LCD screen as shown in the figure and it also sends SMS to the authority in the base station as shown below.



Fig11. Alerting message for tsunami and landslide

7.5. Landslide

When the resistivity changes in the soil level, then soil drift sensor is activated and alerting message is displayed in the LCD screen as shown in the figure and it also sends SMS to the authority in the base station as shown below.



Fig12. Alerting message for landslide

The figure shows the alerting messages in the mobile phone.



Fig13. Alerting Messages

8. APPLICATION, ADVANTAGE AND DISADVANTAGE

8.1. Application

Landslide monitoring is an important topic related at the hill slides. For example, rocky mountain regions of the Konkan Railways, there is possibility of rock fall due to the landslide using this system.

This system is useful for the area where heavy rain fall occur. When sloped areas become completely saturated by heavy rainfall, many times landslides can occur.

This system is useful for the earthquake prone areas like Mumbai, Delhi, Kolkata, Chennai and Nepal. It also includes tsunami warning system is used to detect tsunami's in advance and issue warnings to prevent loss of life and damage.

8.2. Advantage

Multi sensors are used for detecting the different disaster, it is one of the advantage of this system compared to other system that uses multi sensors to detect the single disaster. RF module is used for transmitting the signal from transmitter to receiver if covers the larger distance. GSM module is used for sending the alerting message to the base station authority.

8.3. Disadvantages

This programming is based on microcontroller, so if any corruption occurs in programming, the program will depend on supplier and initial investment cost is more. It can send message to only one person using GSM.

9. CONCLUSION AND FUTURE WORK

The real time system designed for the detection of landslide, tsunami, and earthquake which have been the major hazards. This system is developed using PIC16F877A microcontroller. The main components used in this system are sensors, GSM and RF module.

In the proposed project, various types of real time conditions are tested. In the transmitter section, sensors are connected to PIC processor. If any sensor detected any disturbance, RF transmitter transmits the signal to the RF receiver and it display the alerting message in LCD at receiver using GSM, it can send the message to the authority in the base station. Finally, this project works as per the specification.

In future, this project can be modified by sending the alerting message to the multi users. To increase the performance of this project, the database system can be included to store the real time data.

REFERENCES

- [1] Highland, L & Bobrowsky, P.(2008).“*The landslide hand book-A guide to understanding landslide*”. Reston, Virginia; U.S Geological Survey Circular.
- [2] “*An internet –enabled wireless multi-sensor system for continuous monitoring of landslide processes*” by Kay Smarsly, Kristina Georgieva and Markus König
- [3] “*Earthquake: Simulation, Source and Tsunami*”-Kristy F.Tiampo, Sturat A Weinstein, DionK. Weatherley.
- [4] Mr.Sagar D.Solanki and Mr. Ankit Suthar,“*Wireless Sensor Network For Landslide Assessment*”.
- [5] V.Ramya and B.Palaniappan,“*An Automated Tsunami Alert System*”.
- [6] G.Saradha, “*Simulation of Earthquakes and Tsunami through GSM Network*”.
- [7] Maneesha V. Ramesh,“*Real-time Wireless Sensor Network for Landslide Detection*”.
- [8] Kay Smarsly, Kristina Georgieva and Markus König, “*An Internet-enabled wireless multi-sensor system for continuous monitoring of landslide processes*”.

Textbooks:

- [1] Muhammad Ali Mazidi and Janice Gillespie Mazidi and Rollin D. McKinlay, “*The 8051 Microcontroller and Embedded Systems – using assembly and C*”.
- [2] Mahapatra G.B, “*Physical Geology*”.

Websites:

- [1] http://en.wikipedia.org/wiki/Tsunami_waring_system.
- [2] PIC16F877A Microcontroller datasheet, <http://www.microchip.com/downloads/en/DeviceDoc/41291F.pdf>.
- [3] Tilt sensor datasheet, <http://www.allsensor.com/download.pdf>

AUTHORS' BIOGRAPHY



Arathi.H, Final Year Student in Electronics and Communication Department Moodlakatte Institute of Technology Kundapura, Karnataka.



Archana.M.S, Final Year Student in Electronics and Communication Department Moodlakatte Institute of Technology Kundapura, Karnataka.



Parvati.Madeva.Gond, Final Year Student in Electronics and Communication Department Moodlakatte Institute of Technology Kundapura, Karnataka.



Shayana.A.Hegde, Final Year Student in Electronics and Communication Department Moodlakatte Institute of Technology Kundapura, Karnataka.



Mr.GaneshShetty, Asst.Professor in Moodlakatte Institute of Technology Kundapura Completed Bachelor of Engineering in 2008 under Visvesvaraya Technical University and M.TECH in 2013 under VTU in Jayachamarajendra College Mysore.