

## Dynamic Performance of the Interline Unified Power Flow Controller (IUPFC) System Using 48-Pulse GTO Thyristor

**K Hari Prasad**

PG Student,EEE Department  
St. Johns College of Engg & Tech  
Yemmiganur,Kurnool Dist.,  
A.P, India  
hariprasad0234@gmail.com

**S Tirumalaiah**

Associate Professor,EEE Department  
St. Johns College of Engg & Tech  
Yemmiganur,Kurnool Dist.,  
A.P. India  
sampathi.thirumalesh@gmail.com

---

**Abstract:** *The Interline Unified Power Flow, UPFC, IPFC are Voltage Source Converter (VSC) based Flexible AC Transmission System (FACTS) devices that can control active and reactive power flow in transmission line by means of injection controllable series voltage to the transmission line. This paper proposes a advanced connection for a Unified Power Flow Controller (UPFC) to improve the power flow control of one transmission line in a power system and it regulates bus voltage in another transmission line. It is connected between two different transmission lines, this type of connection of the UPFC will be called an interline UPFC (IUPFC). It is one of the advanced devices within the FACTS technology. The structure and principle Operation of IUPFC with 48-pulse GTO is discussed and its control scheme is based on the d-q orthogonal coordinates. The obtained simulation results from Matlab/Simulink confirm the effective features.*

**Keywords:** *Interline Unified Power Flow Controller (IUPFC) model, UPFC real and reactive power, Flexible AC Transmission System (FACTS), 48-pulse GTO Thyristor Model VSC.*

---

### 1. INTRODUCTION

The UPFC is a device, which can control simultaneously all the three parameters of line power flow which are line impedance, voltage and phase angle [1-2]. It improves terminal voltage regulation, series capacitor compensation and transmission angle regulation [3]. The UPFC is made out of two voltage-source converters (VSCs) i.e. static compensator(SATACOM) and a static synchronous series compensator (SSSC) with semiconductor devices having turn-off capability, sharing a common DC capacitor and connected to a power system through coupling transformers as shown in fig 1The shunt converter is primarily used to provide the real power demand of the series converter at the common DC link terminal from the AC power system. It can also generate or absorb reactive power at its AC terminal, which is independent of the active power transfer to (or from) the DC terminal [5-6].

The series converter is used to generate a voltage at the fundamental frequency with variable amplitude and phase angle, which is added to the AC transmission line by the series connected boosting transformer. The inverter output voltage injected in series with the line can be used for direct voltage control, series compensation, phase shifting, and their combinations. This voltage source can internally generate or absorb all the reactive power required by the different type of controls applied and transfers active power at its DC terminal as depicted in fig 1.

It is also possible to connect two VSCs to two different transmission lines in power system. IPFC has been discussed in which two SSSCs are connected in series with two separate transmission line. The DC buses of the SSSCs are connected together. The IPFC via one from SSSCs absorbs real power from a transmission line and maintains the DC link voltage to control the active and reactive power flow with injection of controllable voltage to another transmission line. Thus UPFC and IPFC inject to the line synchronous voltage of adjustable magnitude and phase angle with separate controlling both the real and reactive power flow in the transmission lines [4], [5]. In this paper, IUPFC as the novel topology is proposed; IUPFC is Interline Unified Power Flow Controller (Interline UPFC), the simplified single line diagram of the system with IUPFC is

shown in Fig.2, It consists of two voltage source converters with separate controllers but sharing a common DC link therefore IUPFC composes STATCOM and SSSC in two separate transmission lines, STATCOM provides the energy of DC-link from the secondary transmission line, it regulates the voltage of DC-link and maintains the bus voltage at constant level in secondary line and it also operates as active filter. The provided voltage of DC- link by means of STATCOM, feeds SSSC till inject a voltage of adjustable magnitude and phase angle in form of series with transmission line via series transformer and it has ability of power flow controlling in wide range. Therefore comparing SSSC and STATCOM it has increased the application abilities, flexible and controlling confine. The performance of the IUPFC has been modeled and simulated using Matlab/Simulink.

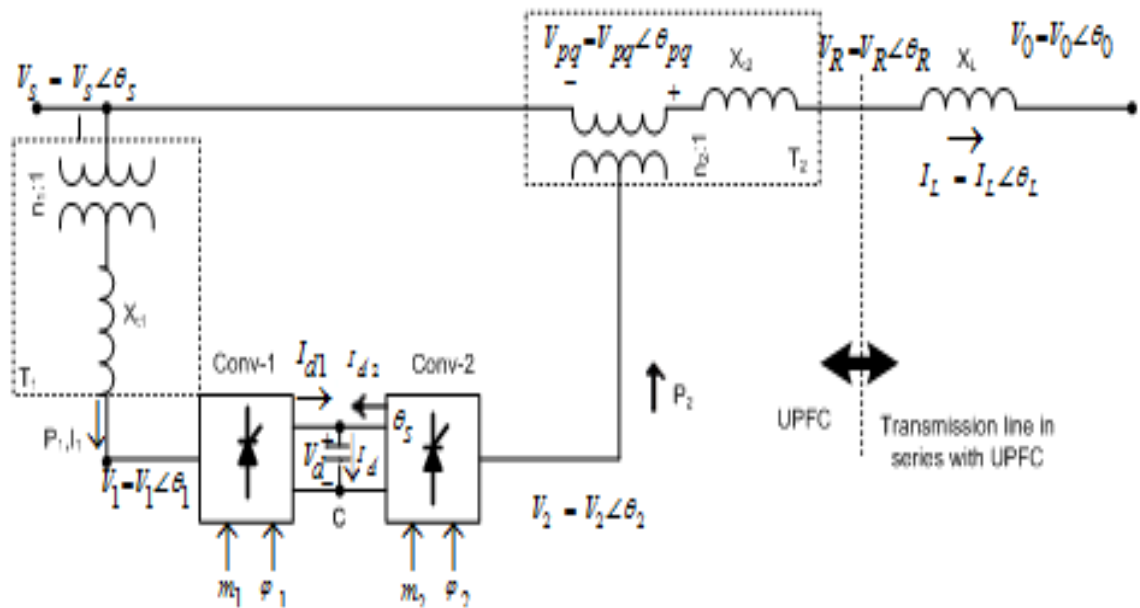

Fig. 1: Implementation of UPFC in transmission line

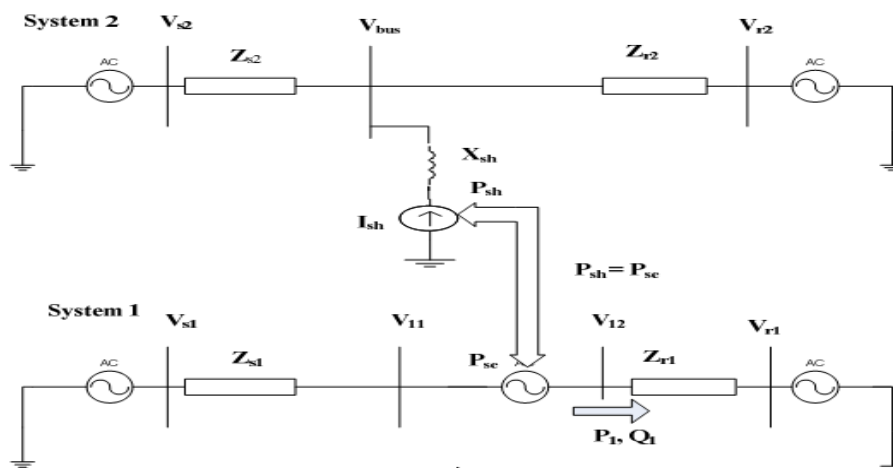

Fig.2. Complete structure of a three-phase IUPFC

## 2. IUPFC MODEL

The complete structure of an IUPFC with two such VSCs is shown in Fig. 3. The example power system consists of two machines in sending-end receiving- end, which is connected by means of two parallel transmission lines. STATCOM and SSSC are connected back to back through a common energy storage dc capacitor C Let us assume that the VSC-1. (SSSC) is connected in

series with transmission line-1 while the VSC-2 (STATCOM) is connected via a shunt transformer to transmission-2; each of the two VSCs is realized by 48-pulse voltage source inverter. The impedances of the line segments connecting the sending-end and receiving-end sources are:

$$Z_{s1} = r_{s1} + jx_{s1}, \quad Z_{s2} = r_{s2} + jx_{s2}, \quad (1)$$

$$Z_{r1} = r_{r1} + jx_{r1}, \quad Z_{r2} = r_{r2} + jx_{r2} \quad (2)$$

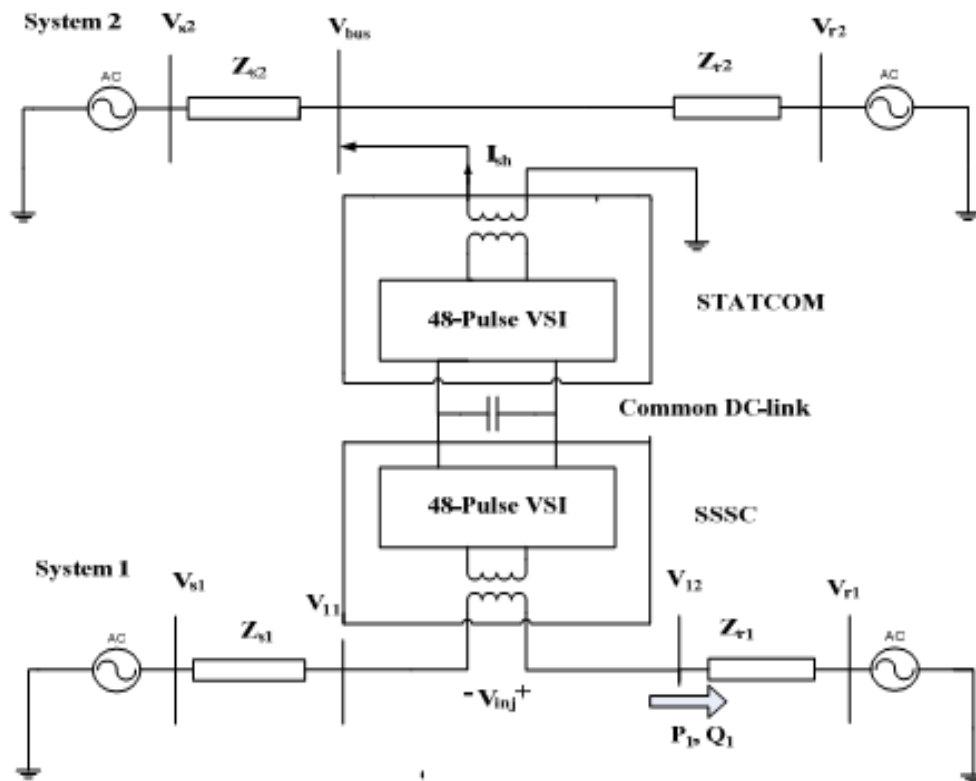

**Fig.3.** Complete structure of a three-phase IUPFC

### 2.1 48-pulse GTO based Diode Clamped Multi Level Converter (DCMLC)

As compared with the other multilevel converters like cascade and flying capacitor converter DCMLC as shown in fig 4 [8] is preferred to configure UPFC converter as it is an interface between the high voltage DC and AC high voltage transmission line[9] . It also shares a common DC bus for all the three phases which not only minimizes the capacitance requirements but also uses back-to-back interconnection, practically such as UPFC. The 1-phase of 5-level converter is shown in fig 4.

### 3. PRINCIPLE OF OPERATION OF IUPFC

IUPFC comprises a number of static synchronous compensators; SSSC and STATCOM in two transmission lines, the compensating converter are connected together via a common DC link. The secondary transmission line help to supply or absorb real and reactive power for injection controllable voltage in series to first transmission line. First transmission line help to provide energy for common DC link till regulate the bus voltage at secondary transmission line and it acts as active filter. The IUPFC developed model in this section is based on the *d-q* orthogonal coordinates [8-10], the steady- state equations between the shunt and series inverters were strictly applied to the model, thus; we can neglect the effect of resistances in the transmission line, thus we have

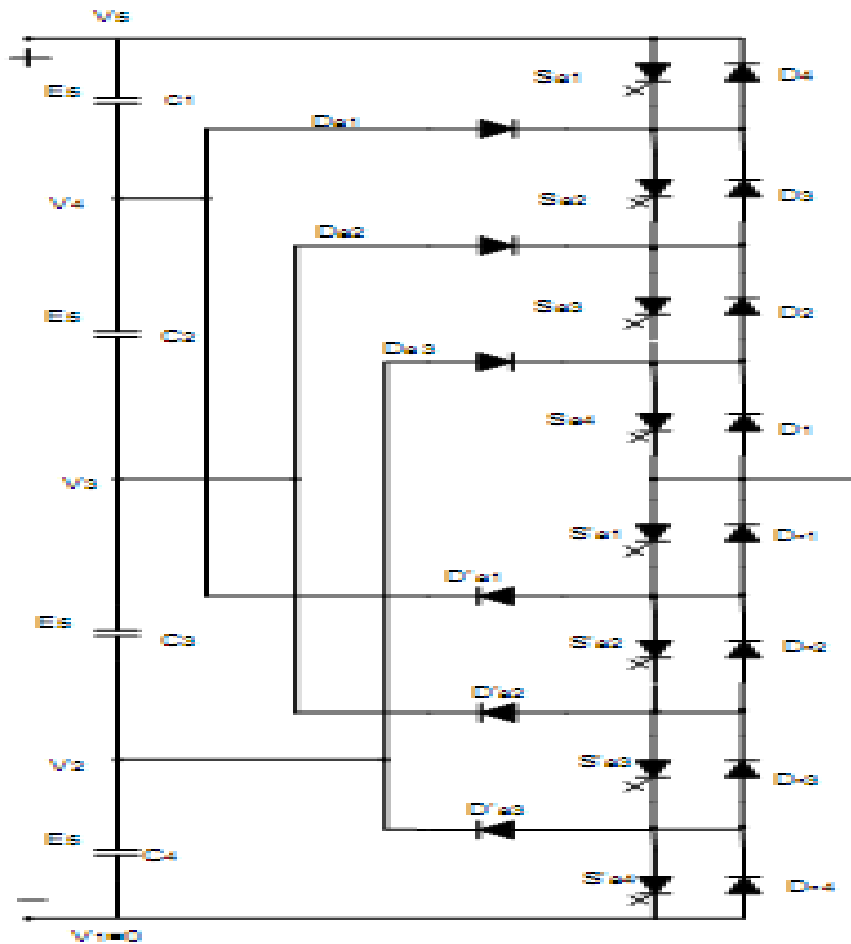

Fig.4 1-phase of 5-level DCML converter

$$P_{sh} = P_{se} \tag{3}$$

$$P_{se} = v_{injd} i_{seq} + v_{injq} i_{sed} \tag{4}$$

$$P_{sh} = v_{busd} i_{shd} + v_{busq} i_{shq} \tag{5}$$

$$Q_{sh} = v_{busd} i_{shq} - v_{busq} i_{shd} \tag{6}$$

We can neglect the effect of resistances in the transmission line, thus we have

$$Z_{r1} = jx_{r1} \tag{7}$$

$$V_{11} + V_{inj} = V_{r1} + j x_{r1} I_{se} = V_{seff} \tag{8}$$

$$P_1 = \frac{v_{seff} v_{r1} \sin \delta_1}{x_{r1}} \tag{9}$$

$$Q_1 = \frac{v_{seff} (v_{seff} - v_{r1}) \cos \delta_1}{x_{r1}} \tag{10}$$

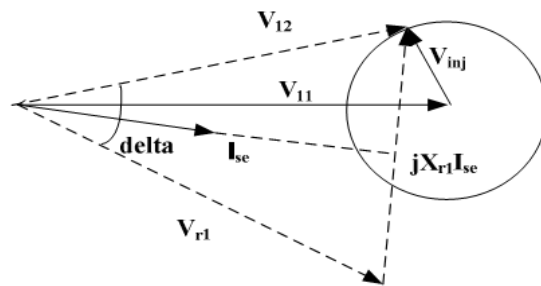

Fig.5 Phasor diagram of voltage and current

#### 4. CONTROLLING ALGORITHM

Control of the series branch is different from the SSSC. In a SSSC the two degrees of freedom of the series converter are used to control the active and the reactive power. The proposed controlling system accomplished by either direct control of the line decoupled current control strategies by the indirect control. The shunts converter acts as a STATCOM. For a description of its control system, the shunt converter controls the AC voltage at another transmission line and regulates the voltage of the DC bus. It uses d-q controlling algorithm for the regulation of them. The simplified block diagram of the series converter is shown in fig.6.

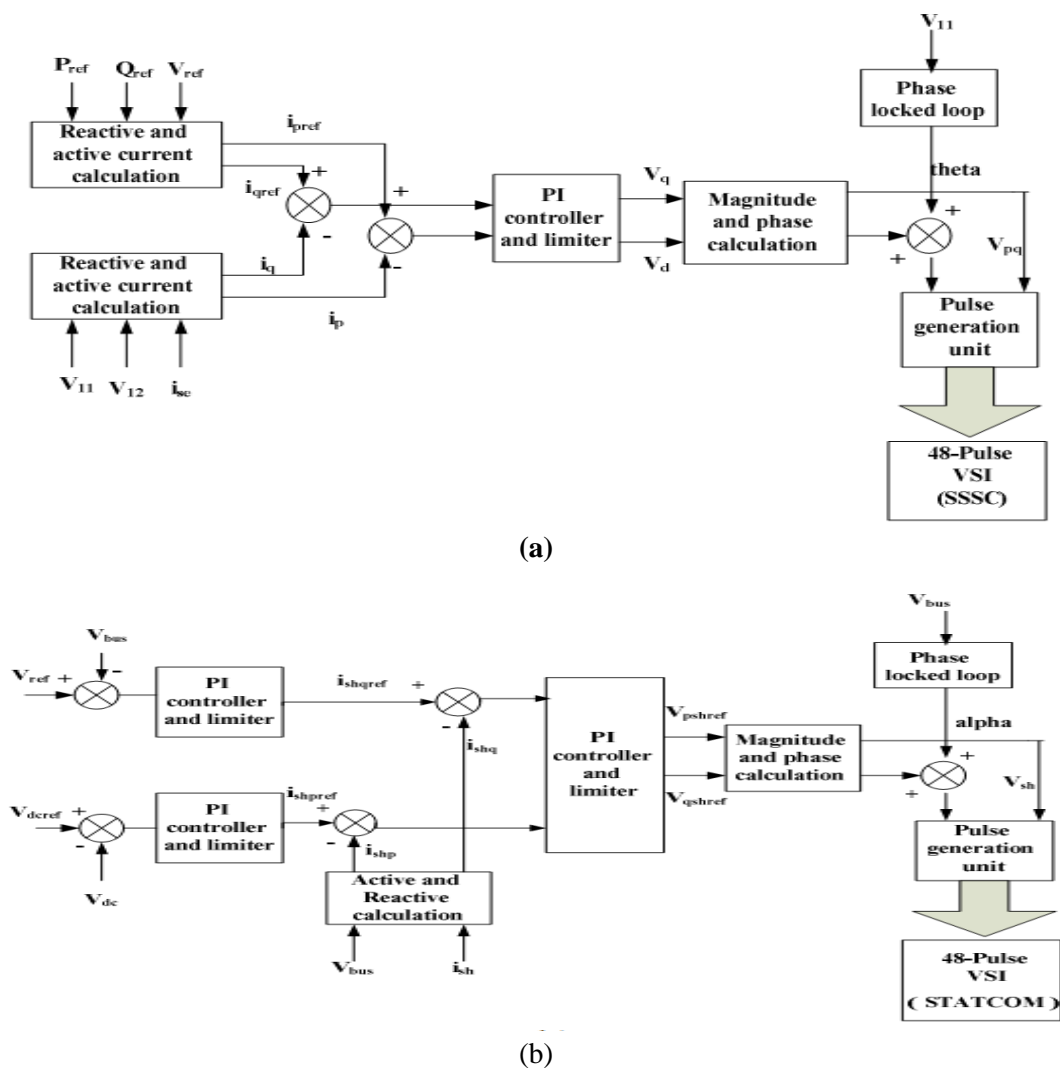

Fig. 6 Simplified control block diagrams of the: (a) series converter in System 2, (b) shunt converter in two systems

### 5. SIMULATION RESULTS

The proposed converter is modeled and analyzed by Matlab/Simulink and is shown in fig 7.

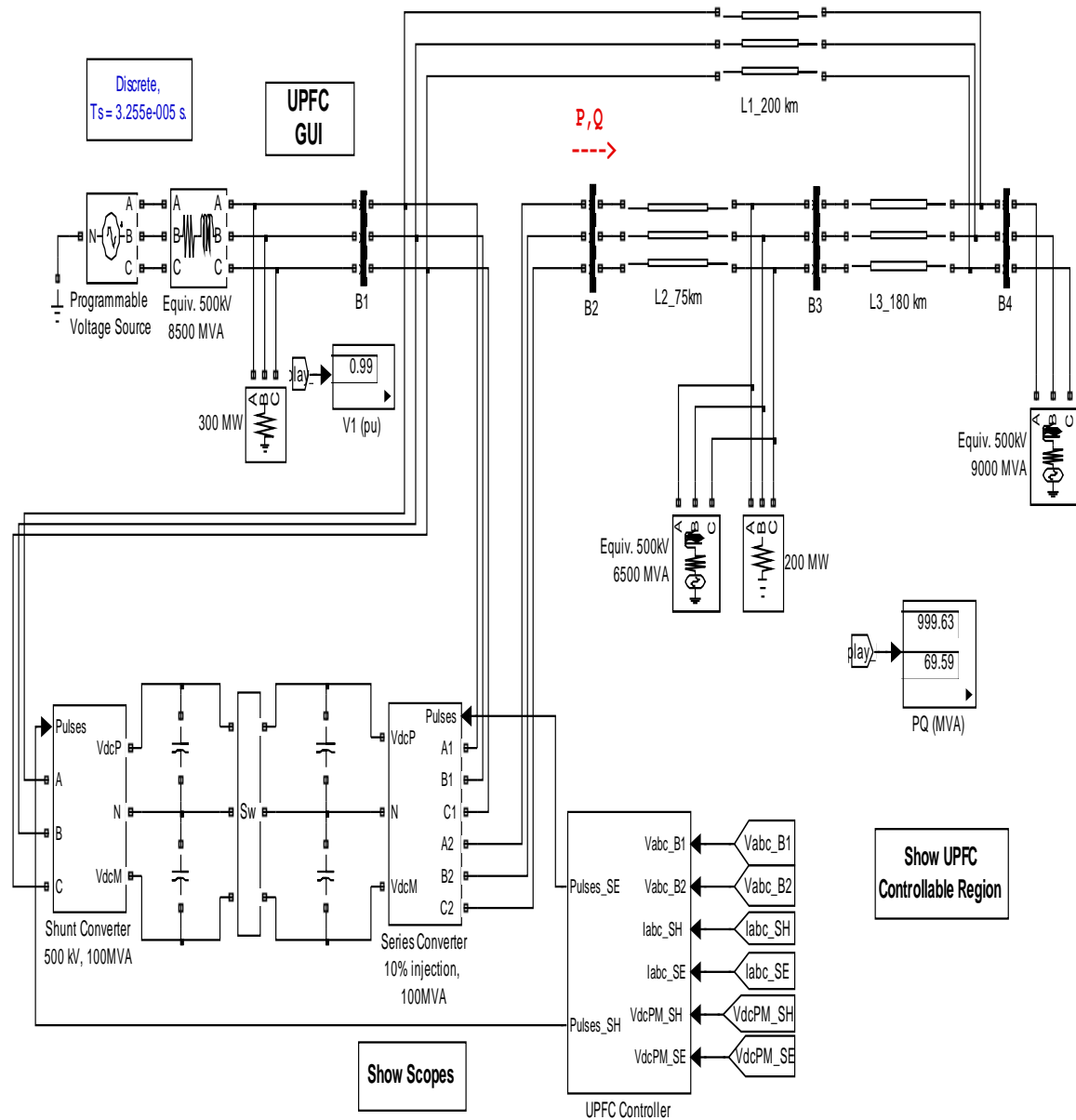

Fig. 7: Simulation model of 48-pulse GTO-based UPFC

Fig.8 illustrates real and active power flow control in dynamic condition and injected series voltage, crossing current from transmission line1.

At first, the transmitted power in transmission line 1, after a transient period lasting approximately 0.1 sec, the steady state is reached ( $P=+8.7$  PU;  $Q=-0.6$  PU). Or  $S = +8.7-j0.7$  (PU).

At  $t=0.7$ sec  $P_{ref}$  is changed to +10 PU (+1000MW) and  $Q_{ref}$  is changed to +0.7 PU (+70 MVAR), Then P and Q are increased in form of ramp to the new settings ( $P=+10$  PU,  $Q=+0.7$  PU).

## Dynamic Performance of the Interline Unified Power Flow Controller (IUPFC) System Using 48-Pulse GTO Thyristor

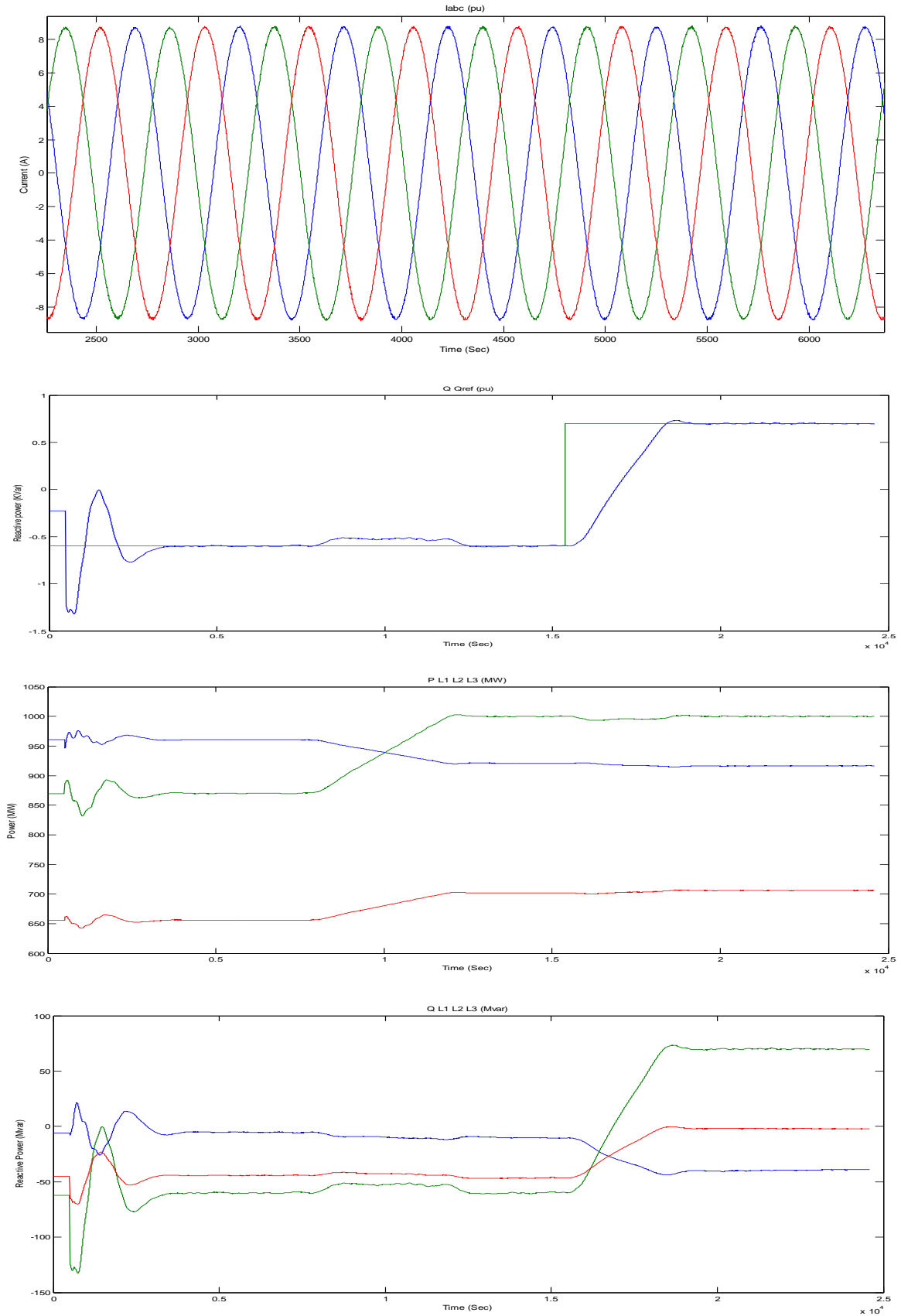

**Fig. 8:** performance of real and active power flow control in dynamic condition and injected series voltage, crossing current from transmission line

The series inverter controls the magnitude and angle of the voltage injected in series with the line. By varying the phase and magnitude of series voltage injected power flow through the transmission line can be varied.

Fig.9 shows regulation of voltage, injected reactive power flow and common DC-link voltage in dynamic condition in transmission line 2, around time of  $t=2$  sec when  $Q$  is changed from  $+0.8$  PU to  $-0.8$  PU. When  $Q=+0.8$  PU, the current flowing into the STATCOM is lagging voltage indicating that STATCOM is absorbing reactive power.

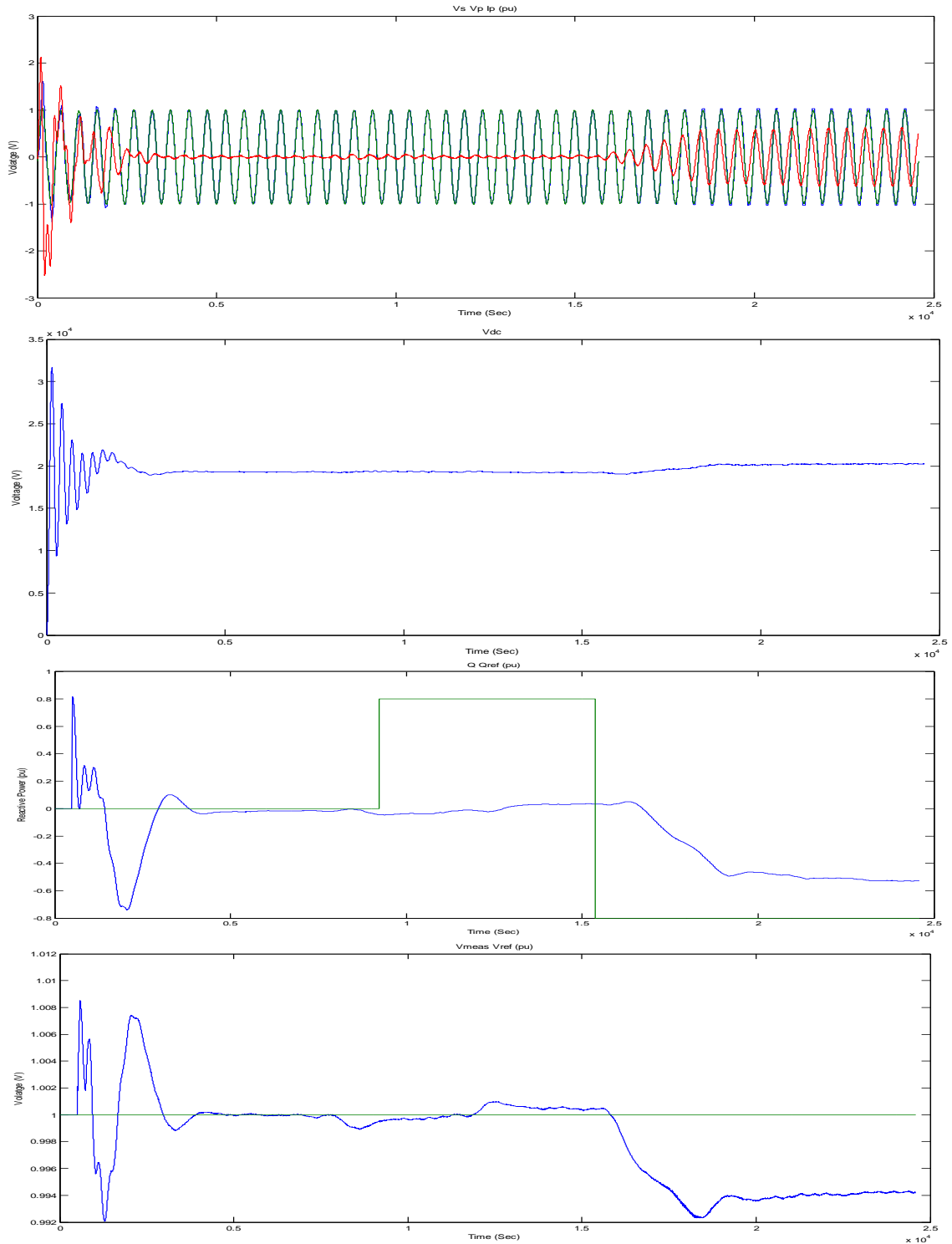

**Fig. 9** performance regulation of voltage, injected reactive power flow and common DC-link voltage in dynamic condition STATCOM with injection of reactive power regulates the bus voltage in another transmission line.



## **6. CONCLUSION**

This paper presents the design of new topology of combined from SSSC and STATCOM. IUPFC can control active and reactive power flow in first transmission line with injection of controllable voltage in the form of series in wide range and shunt inverter (STATCOM) in secondary transmission line, as active filter, compensates unbalance line current and it regulates the bus voltage and DC link voltage. The control strategies implement decoupled current control and auxiliary tracking control based on a pulse width modulation switching technique to ensure fast controllability, simple implementation comparing with series and shunt compensator and controlling algorithm is based on d-q principal and 48-pulse multilevel inverter. The propose system is modeled and analyzed using Matlab/Simulink and simulation results verified the proposed combination for IUPFC which operates accurately.

## **REFERENCES**

- [1] Y. Ye, M.Kazerani, "Power flow control schemes for series-connected FASTS controllers. Electric Power Systems," Research76(2006)824- 831, 14 Oct 2005 '
- [2] R. Orizondoand R. Alves, "UPFC Simulation and Control Using the ATP/EMTP and MATLAB/Simulink Programs," IEEE PES Transmission and Distribution Conference and Exposition Latin America, Venezuela, Aug 15- 18, 2006
- [3] A. Ajami, S.H. Hosseini, and G.B. Gharehpetian, "Modelling and Controlling of UPFC for Power System Transient Studies,"ECTITransonElectricalENG.,Electronics,andcommunications,VOL.5,NO.2August2007
- [4] N. G. Hingorani, L. Gyugyi, "Concepts and Technology of Flexible AC Transmission Systems," IEEE Press, John Wiley & Sons, 2000.
- [5] V. Azbe, R. Mihalic, "Energy function for an interline power-flow controller, Electric Power Systems," Research 79 (2009) 945–952, 16 Dec 2008
- [6] C. Dufour, J. Bélanger, "Real-time Simulation of a 48-Pulse GTO STATCOM Compensated Power System on a Dual-Xeon PC using RT-LAB," International Conference on Power Systems Transients (IPST'05) in Montreal, Canada on June 19-23, 2005 Paper No. IPST05 - 253
- [7] TahaSelimUstun and SaadMekhilef, "A Quasi- resonant Soft Switching 48-pulse PWM Inverter with Closed Loop Current Control for the Realization of Static Synchronous Series Compensator (SSSC) ," Australian Journal of Basic and Applied Sciences, 3(3): 1814-1826, 2009, ISSN 1991-8178
- [8] [8] Myung-Bok Kim, Gun-Woo Moon and Myung-JoongYoun, "Synchronous PID Decoupling Control Scheme for Dynamic Voltage Restorer against a Voltage Sag in the Power System," 35th Annual IEEE Power Electronics Specialists Conference, pp. 1046-1051, 2004
- [9] S. T. Kalyaniand G. T. Das, "Simulation of D-Q control System for a Unified Power Flow Controller," Asian Research Publishing Network (ARPN), ISSN 1819-6608, VOL. 2, NO. 6,Dec 2007
- [10] H. Fujita, Y. Watanabe and H. Akagi, "Dynamic Control and Performance of a Unified Power Flow Controller for Stabilizing an AC Transmission System," IEEE Trans. Power Elect, vol. 21, no. 4, pp.1013-1020, July,2006.

**AUTHORS' BIOGRAPHY**



**K HARI PRASAD** was born in the year 1988. He is graduated from JNTUA Ananthapuram, Andhra Pradesh in the year 2010. Presently he is pursuing his M.Tech with Power Electrical and Electrical Drives in St. Johns College of Engineering and Technology, Yemmiganur, Kurnool Dist, Andhra Prasad



**S. THIRUMALIAH** has obtained his B.TECH from S K University, in the year 2002. He has obtained his M.Tech from JNTU Hyderabad in the year 2008. He has 6 years of teaching experience, presently he is a research scholar in JNTU Anantapur. He is working in the area of power system quality control with application of power electronics.



**A. MALLIKARJUNA PRASAD** has obtained his B.E from MADRAS University in the year 2001. He has obtained his M.E from Satyabama University in the year 2004. He has 9 years of teaching experience, presently he is a research scholar in JNTU KAKINADA. He is working in the area of High power density dc-dc converters.